



GLASS CANOPIES



CONTENTS

GLASS CANOPIES BY SOLARLUX 04

THE BENEFITS OF CHOOSING A PREMIUM MANUFACTURER 06

THE DIVERSITY OF GLASS CANOPIES 22

The SDL Acubis

The SDL Alerio

The SDL Atrium plus

The SDL Aura

FROM GLASS CANOPY TO GLASS HOUSE 34

FITTING OPTIONS FOR GLASS CANOPIES 40

SYSTEM FEATURES - COMPARISON 46

THE TECHNOLOGY OF THE GLASS CANOPIES 50

ABOUT SOLARLUX 60

GLASS CANOPIES BY SOLARLUX

For certified quality in your garden

The demands placed on a glass canopy can vary greatly depending on the situation: protection from wind and weather is often a priority, but the desire to be able to spend more time outdoors is also a common factor in opting for a glass canopy. In addition to this, a glass canopy also provides a permanent location for storing garden furniture and plants over the winter months.

Solarlux has more than 35 years of experience in producing wintergardens, glass houses and bi-folding doors. A glass canopy from the German premium manufacturer not only offers optimum weather protection - it also provides you with the assurance that you have chosen a provider to whom certified quality and compliance with the applicable regulations are of the utmost importance.





A SAFE HAVEN - REAL EXPERTS YOU CAN *trust*

THE BENEFITS OF CHOOSING A PREMIUM MANUFACTURER

THE RIGHT CHOICE IN EVERY RESPECT

The perfect solution for any situation

Accurately fitting solutions by Solarlux. Whether you choose a glass canopy or a glass house with vertical glass elements, every system will be the perfect match for the architecture of your building as well as your needs. Solarlux's bespoke solutions are also impressive in terms of their design: the canopies, shade features and vertical glass elements are conceived precisely to work in perfect harmony with one another, right down to the smallest detail. All Solarlux products come from a single source - thus guaranteeing full functionality for many years to come.



APPLICATIONS

Glass canopies and glass houses cater to a wide range of applications - "traditional" patio roofing is just one of many possibilities. Our wide range of canopy designs - each of which is perfectly tailored to suit your individual project - is also suitable for use as an integrated roof system, a sheltered pergola, or to extend outdoor seating areas in the gastronomy industry.

Gastronomy · Langenfeld, Germany

Integrated roof system · Düsseldorf, Germany



Stand-alone glass house
Rhosneigr, UK



EXAMPLES OF CANOPY SHAPES

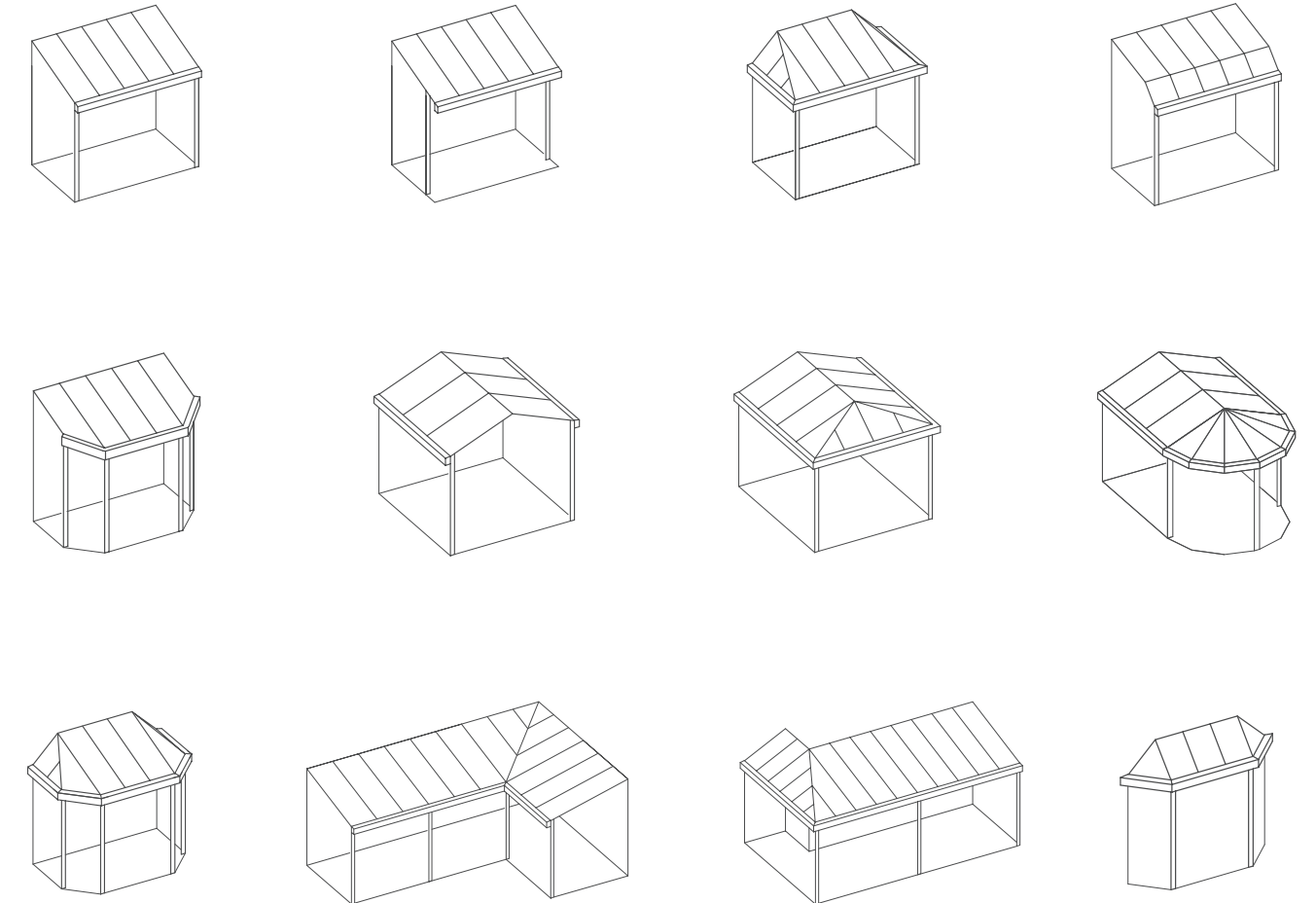

WIDE RANGE OF CANOPY SHAPES

Whatever your stylistic tastes, Solarlux glass canopies guarantee the right shape of canopy for any situation. Glass canopy, glass house, car port or entrance canopy: our in-depth planning and consultation services will allow us - together with the client - to determine the perfect shape and size to suit their ideas and wishes. Design, structural specifications, drainage, shading and ventilation - these are the key factors that help us to design the perfect roof construction and bring it to life.



TESTED SOLARLUX QUALITY MADE IN GERMANY

Test certificates from reputable national and international institutes guarantee the highest level of functional reliability, stability and durability for every Solarlux glass canopy and glass house. The fully tested structural specifications offer peace of mind in extreme weather conditions, such as snowfall leading to snow drifts, high winds and even hurricanes. In addition to complying with the glass standard DIN 18008, it goes without saying that all our systems also bear the CE marking. This European seal of approval confirms that Solarlux offers compliance with DIN EN 1090, which has been mandatory for all manufacturers of steel and aluminium supporting structures since 2014. This system is used throughout Europe to demonstrate when a factory has been certified and carries out its own production control.

NOTE:

DIN EN 1090 is extremely important. If this certification is not provided, your planning permission may be rejected.

OUR MATERIALS

The high-quality aluminium and wood materials we use at Solarlux offer maximum creative freedom for your design - not to mention sustainability and durability. By combining these materials with our patented technology, we can make the Solarlux glass canopy the perfect designer solution for your construction projects.



WOOD

The natural material for a cosy environment

The woods used by Solarlux are FSC® and PEFC™-certified, and are sourced from sustainable forestry. Both our certificates in this area set high standards, particularly in terms of sustainability, the environmental sustainability of the forest cultivation, the quality of the work and the social expertise of the forestry companies we work with. Our use of water-based finishes and energy-saving production with recycling of water and heat provide further evidence of the care with which we handle our natural resources.

This means that when you choose wood as your material, you are opting for a natural raw material that will provide individual and cosy living. Solarlux fulfils this preference in every respect. In addition to spruce and pine, we also offer a wide range of other timbers, depending on the grain. Our surface treatments are completely individual too. Whether you opt for a varnish, a hand-oiled surface or an opaque lacquer, Solarlux products are available in any colour of your choice, regardless of the product manufacturer.



ALUMINIUM

The material for durability

Durable and almost completely zero-maintenance - this is the promise that aluminium keeps as a material. We also apply environmental awareness to our aluminium production - Solarlux is certified in accordance with the German A.U.F. Recycling Loop, which has confirmed that our aluminium is recycled in an environmentally conscious manner that saves on resources. All of our aluminium glass canopies are available in any colour - including special colours such as Eloxal and DB.

OUR COLOURS

When you choose a Solarlux glass canopy, you opt for individuality. Solarlux standard colour options, which include around 30 RAL colours, offer all the colours of the rainbow in matt and gloss finishes, at no extra cost. This allows every glass canopy to match its building's interior and exterior design. We use our own in-house coating plant - one of the most modern in Europe - for top surface quality.

THE SOLARLUX WORLD OF COLOURS

 RAL 1015	 RAL 3011	 RAL 5003	 RAL 5008
 RAL 5014	 RAL 6005	 RAL 6009	 RAL 7004
 RAL 7006	 RAL 7015	 RAL 7016	 RAL 7021
 RAL 7024	 RAL 7035	 RAL 7038	 RAL 7039
 RAL 7040	 RAL 8017	 RAL 8019	 RAL 8022
 RAL 8077	 RAL 9001	 RAL 9003	 RAL 9004
 RAL 9005	 RAL 9006	 RAL 9007	 RAL 9010
 RAL 9011	 RAL 9016		



SOLARLUX SPECIAL COLOURS

Distinctive finishes for unique projects

It goes without saying that we also offer special DB, RAL and Eloxal colours, as well as special surface finishes (e.g. Tiger) for anyone looking to give their glass canopy a unique twist. We can make almost any wish come true - and we also offer coatings for special climate requirements (such as coastal properties).

**THE SOLARLUX COATING IS CERTIFIED
TO INTERNATIONAL STANDARDS**



THE ADVANTAGES OF THE GLASS CANOPY - AN OVERVIEW



PROTECTION FROM WIND AND WEATHER

With a glass house, you can enjoy your patio at any time of year. The versatile glass elements provide additional protection from draughts without obscuring your view. And with our all-round weather protection, you'll soon find your evenings on the patio stretching out into the small hours - whatever the weather.



PROTECTION FOR PLANTS AND GARDEN FURNITURE

No more wasting time constantly carrying your garden furniture and patio plants in and out of the house! A glass house will provide excellent protection for your plants and furniture, all year round.



BOOST THE VALUE OF YOUR PROPERTY

Glass canopies and glass houses are a sure-fire way of increasing your property's value. Thanks to their different shapes, colours and materials, you can always find a Solarlux glass canopy to match the architecture of your home. Their functionality and, above all, their high-quality design represent guaranteed added value, for new buildings and renovations alike.



HEAT BARRIER

The glass house does more than offer protection from the wind and rain - it also acts as a heat barrier: simply open the door to your main living area on a warm autumn or winter day and let the heated air from the glass house warm up the rest of your home.



WHAT SOLARLUX OFFERS

- In-depth consultation and planning
- Free visualisation (e.g. virtual reality model)
- Wide range of shapes, materials and colours guarantees perfect harmony with the building's existing architecture
- Filigree profile views, maximum transparency
- Silicone-free assembly
- Sophisticated technical construction in terms of drainage, sealing, structural specifications and sub-structure
- Compliance with all applicable standards and specifications



MAKE YOURSELF *at home* IN YOUR GARDEN

THE DIVERSITY OF GLASS CANOPIES



TAILOR-MADE TO SUIT YOUR EVERY WISH

Every Solarlux glass canopy and glass house is a bespoke solution that is tailor-made to suit your individual needs. With the wide range of systems we offer, anything is possible: from quickly and efficiently made glass canopy constructions and sophisticated designer roofing to complex custom solutions.

**A GLASS HOUSE OFFERS THE
PERFECT SHELTERED ENVIRONMENT
TO WHILE AWAY THOSE LONG
EVENINGS**



SDL ACUBIS

ALUMINIUM

The flat canopy with sophisticated technology

The new SDL Acubis flat canopy is a winner in terms of design and functionality, and can be built as a stand-alone construction or an extension to an existing building. The internal structural reinforcement of the non-insulated profile system lends the canopy an air of elegance. The 2° roof pitch is barely visible to the naked eye, but is enough to ensure that water drains off the canopy. A low, single-piece wall joint lends the canopy a lightweight look and makes on-site assembly a breeze.

THE SDL ACUBIS

- Invisible 2° roof pitch
- Low fascia - just 253 mm
- Stand-alone construction or connected to your existing architecture
- Can be extended to form a glass house
- Comprehensive range of accessories available: lighting, shading, etc.





SDL ALERIO

ALUMINIUM

An elegant glass canopy with internal structural members

The SDL Alerio glass canopy is Solarlux's latest system. It is a great fit for any style of building architecture, from elegant to modern, and its internal structural members lend it a particularly striking appearance. Its profiles, which have been specially designed for this application, can be used to build incredibly delicate-looking constructions. The roof can be designed as a monopitch roof with a pitch of between 5° and 20°. The SDL Alerio can be built to suit your requirements in terms of size and structural dynamics - while still maintaining an impressively slender and delicate appearance.

THE SDL ALERIO

- Roof pitch: 5° to 20°
- Single glazing made of laminated safety glass with a thickness of 8, 10 or 12 mm
- Two different pillars, depending on version
- Variable pillar positioning
- Concealed drainage available in pillars
- System can be expanded using a variety of vertical glazing options to create a closed-off or partially closed-off glass canopy or non-insulated glass house

SDL ATRIUM PLUS

ALUMINIUM

The all-round solution to suit any situation

The perfect glass canopy for any application: the Atrium plus allows you to create extremely large areas of glass with immense spans - and complex special shapes, too. Its elegant design and filigree Softline profile lend the canopy an incredibly airy character, while the permanent roof ventilation system keeps the climate comfortable at all times. It also offers an impressively high level of prefabrication and short assembly times. When combined with the SL 20e vertical sliding system, fixed glazing or the tried-and-tested SL 25 slide-and-turn system, the glass canopy can be transformed into a glass house with protection on all sides.

THE SDL ATRIUM PLUS

- Roof pitch: 5° to 45°
- Suitable for very large canopy and roof areas
- Available in almost any shape
- Can be extended to form a glass house
- Comprehensive range of accessories available: lighting, shading, etc.
- With optional roof overhang





SDL AURA

WOOD/ALUMINIUM

Get close to nature

This glass canopy system will bring you closer to nature in two ways: the wood on the inside of the canopy makes it a unique, natural product, while the aluminium covers on the outside allow you to be closer to the natural world while still being protected from the weather. The covers are available in any RAL colour, thus ensuring that the SDL Aura matches the exterior design of your building perfectly. The system also offers a number of design benefits, such as optimum protection from the elements and surface-mounted spotlight rails. The SDL Aura comes in laminated spruce as standard; other types of wood are available on request.

THE SDL AURA

- Roof pitch: 5° to 25°
- Wood: Spruce
- Slender dimensions and incredibly sturdy thanks to use of the perfect wooden materials
- High level of prefabrication
- Optimum weatherproofing of rafters and eaves thanks to the externally mounted cross-beam
- Optional roof overhang at side
- Interior or exterior shading available



PERFECT *protection* ON ALL SIDES

FROM GLASS CANOPY TO GLASS HOUSE



AN UNOBSTRUCTED VIEW OF PARADISE

Sliding systems, slide-and-turn systems & bi-folding doors

A glass canopy is a good place to shelter under on rainy days. Yet if you add vertical, sliding glass elements, it becomes a glass house that will protect you against all types of wind and weather. Almost any Solarlux glass canopy can be converted into a cosy glass house – even after the original installation. The benefits: a Solarlux glass house is transparent on all sides, causes no reduction in daylight, and can be opened up fully on all elevations. Enjoy the fresh air to its fullest when the weather is nice, then close the transparent vertical glazing for protection against wind and rain when the conditions turn.

[VIEW OUR ENTIRE PORTFOLIO](#)
[OF VERTICAL ELEMENTS](#)
[AT SOLARLUX.COM](#)





SL 20E SLIDING SYSTEM

All-glass, non-insulated

The SL 20e sliding system can be used in glass canopies to protect from the wind and weather, or as a simple partition. Its ease of use is particularly impressive: the intelligent catching function makes moving the all-glass elements child's play. The individual panels are guided along two to five-track flat running tracks, providing an accessible transition to the outdoors. In addition to this, the SL 20e sliding system can be used as a fully transparent corner solution without any loss of impermeability. The elements can be set up to slide to the left and/or the right, and a framed variant and a locking mechanism with a range of different handle designs are available as options.

SL 25/SL 25 XXL SLIDE-AND-TURN SYSTEM

All-glass, non-insulated

The SL 25 and SL 25 XXL slide-and-turn systems are an excellent choice for anyone looking for protection from the wind and weather, and are also available with frames for more demanding situations. The elements can be set up to slide to either the left or the right, and to swing either inwards or outwards. The carriages can move through any angle between 90° and 180°, which makes the systems perfect for a wide range of floor plans and offers unrestricted creativity when designing your patio. Thanks to this technology, the elements can be opened across almost their entire width, with only a thin bundle of panels stacked to one side. This allows you to enjoy the full effect of the fresh air on your patio when the weather is good.

SL 35/SL 45 BI-FOLDING DOOR

Aluminium, non-insulated

The SL 35 and SL 45 bi-folding doors offer excellent protection from the wind and weather thanks to their use of two continuous sealing levels. They fold up like an accordion, leaving a large opening to let the fresh air into your glass house. Depending on the system, the slender bundle of panels can be slid to the left or right and fold inwards or outwards, leaving a panel bundle of just 50 centimetres in a five-meter opening, for example.





MAXIMUM
CONVENIENCE FOR YOU,
EVERYTHING *included*

FITTING OPTIONS FOR GLASS CANOPIES



THE LATEST SHADING TECHNOLOGY

The Solarlux awning made by Warema

Maximum shading convenience for Solarlux glass canopies: Solarlux awnings made by Warema, which are tailored exactly to fit the glass canopies, guarantee a wide range of technical and functional benefits. They can even be used to fit awnings onto large-area canopies. The range of different materials and colours available offers plenty of creative freedom, while all-glass sliding elements can also be combined with the vertical awning. The Solarlux awning made by Warema is available in four variants: above glazing, below glazing, vertical and corner. Both the awning and the glass canopy are delivered to the building site in the same shipment and can be ordered directly through Solarlux, who act as a one-stop shop for service and delivery to both building owners and on-site installers.



FOR A PERFECT LIFE IN YOUR GARDEN

Wide range of accessories direct from Solarlux

We don't just offer optimum shading, pleasant temperatures on colder days, ventilation on hot days, lighting or special glazing as ways of making your glass house the perfect cosy corner for your home. We also make it easy for you to control these components at the push of a button. And the convenience and practicality don't stop there: everything is provided directly by Solarlux - the one-stop shop for all your glass house needs.



MOBILE CONTROL SYSTEM

The innovative Solarlux control system doesn't just allow you to control your high-quality awning remotely - you can also use it to dim your lighting or switch it on and off. It is also easy to expand the control system so that it can be used on up to eight different products (e.g. radiant heaters). You can even download an app to control all your components using your smartphone.

VENTILATION

Permanent roof ventilation with two panes of glass provides a constant flow of fresh air to your glazed patio or glass house, stopping it from getting too stuffy even on hot days. Optional electric skylights, lift-and-slide windows and sliding skylights are also available.



RADIANT HEATER

The designer radiant heater is the perfect temporary heating solution for your glass house. Simply switch it on shortly before you start using the glass house and you'll be enjoying its pleasant warmth in no time - with great accuracy, whenever you need it.

LIGHTING

Enjoy balmy summer nights on your patio. Integrated LED spotlights create a cosy twilight atmosphere and provide pleasant illumination under your glass canopy.



GREAT DIVERSITY REQUIRES *clarity*

SYSTEM FEATURES - COMPARISON

OVERVIEW OF THE SYSTEMS

Next is an overview of all our systems and options so that you can compare them with just a quick glance.

	SDL Acubis	SDL Alerio	SDL Atrium plus	SDL Aura
Material				
Aluminium	●	●	●	○
Wood/aluminium	○	○	○	●
Canopy shapes				
Monopitch canopy	●	●	●	●
Segmented canopy shape	○	○	●	○
Customised designs	○	○	●	○
Dimensions ⁽²⁾				
Max. distance between pillars	7 m	7 m	7 m ⁽¹⁾	5 m ⁽¹⁾
Max. width	Unlimited	Unlimited	Unlimited	Unlimited
Max. depth	6.1 m	7 m	7 m	5 m
Roof pitch	2°	5 - 20°	5 - 45° ⁽³⁾	5 - 25° ⁽³⁾
Drainage				
Designer gutter	●	●	●	●
Drainage via downspout	○	●	●	●
Drainage via downpipe	●	●	●	●
Shading				
On outside	○	●	●	●
On inside	●	●	●	●
Vertical	●	●	●	●
Ventilation				
Permanent roof ventilation with fly screen	○	○	●	○
Motorised roof ventilation	●	●	●	●
Motorised sliding windows	●	●	●	●
Lighting				
Rafters with LEDs	●	●	○	○
Spotlight rail with LEDs	●	○	●	●
Cable duct	●	●	●	●
Suspended system for Solarlux glass houses				
SL 25/SL 25R/SL 25 XXL slide-and-turn system	●	●	●	●
SL 20e/SL 20Re/SL 23 sliding system	●	●	●	●
SL 35/SL 45 bi-folding door	●	●	●	●
Fixed glazing	●	●	●	●

⁽¹⁾ Additional canopy shapes available on request
⁽²⁾ Depending on snow load, beam spacings and weight of glass
⁽³⁾ Additional roof pitches available on request

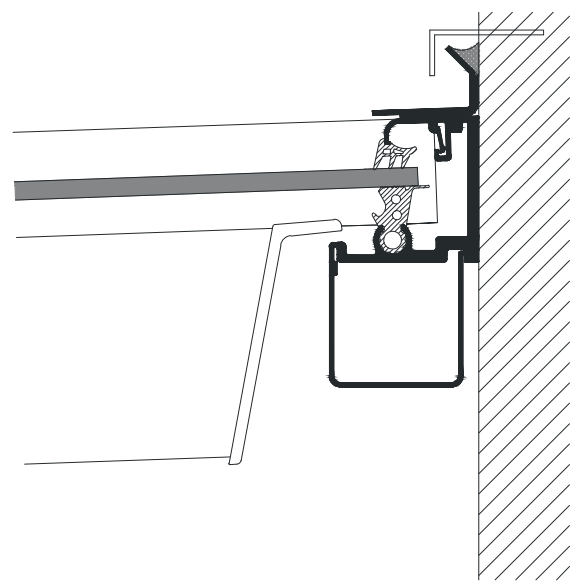

THE TECHNOLOGY OF THE GLASS CANOPIES

THE SDL ACUBIS

Wall joint
Rafters
Eaves

THE SDL ATRIUM PLUS

Wall joint
Rafters
Eaves

THE SDL ALERIO

Wall joint
Rafters
Eaves

THE SDL AURA

Wall joint
Rafters
Eaves

SDL ACUBIS

Detail sections

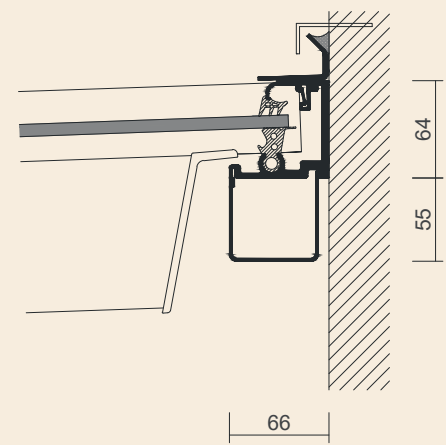

WALL JOINT

- One-piece wall joint
- Cable duct for concealed cable routing

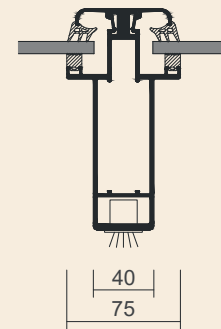

RAFTERS

- Filigree, inside rafters with lighting
- Available with steel reinforcement for heavy snow loads

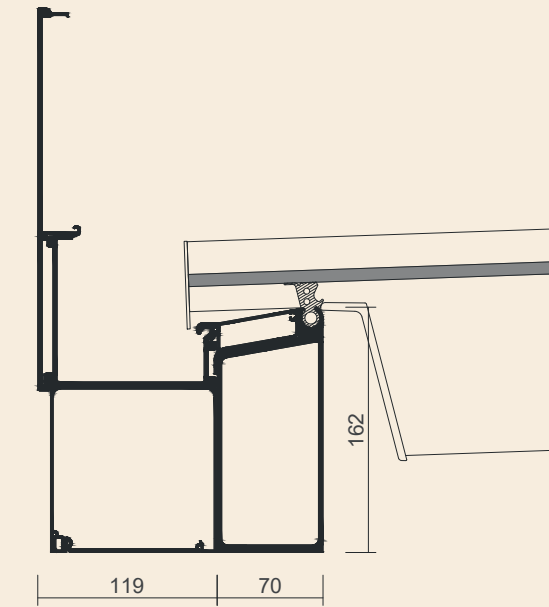

EAVES WITHOUT ROOF OVERHANG

- Three-piece component comprising eaves, gutter and the 253 mm facing;
- Available with optional lighting or shading profil

SDL ALERIO

Detail sections

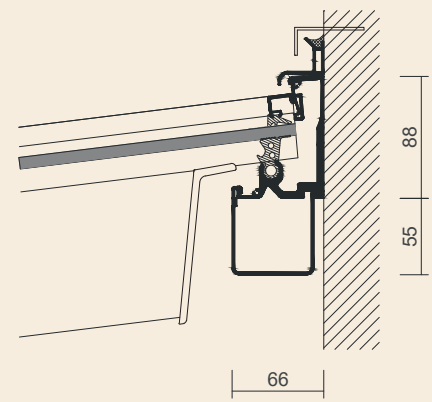

WALL JOINT

- One-piece wall joint
- Cable duct for concealed cable routing

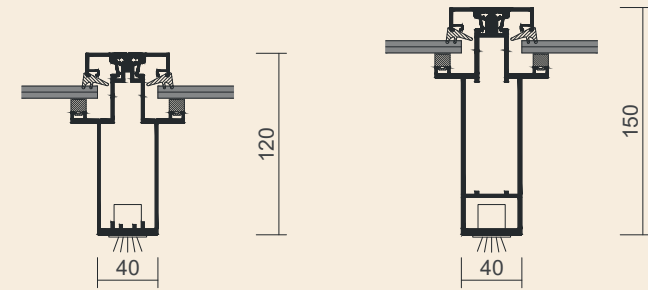

RAFTERS

- Filigree, inside rafters with lighting
- Available in two different sizes depending on structural requirements for high snow loads

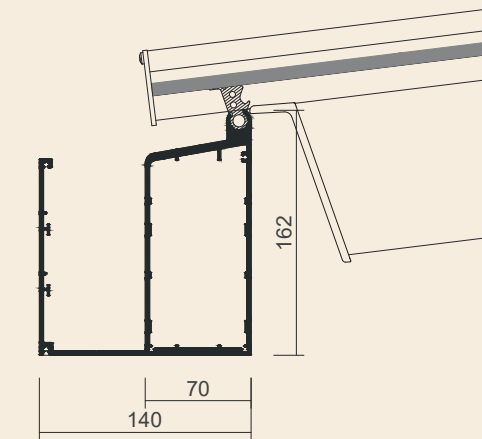

EAVES

- One-piece eaves with square gutter profil

SDL ATRIUM PLUS

Detail sections

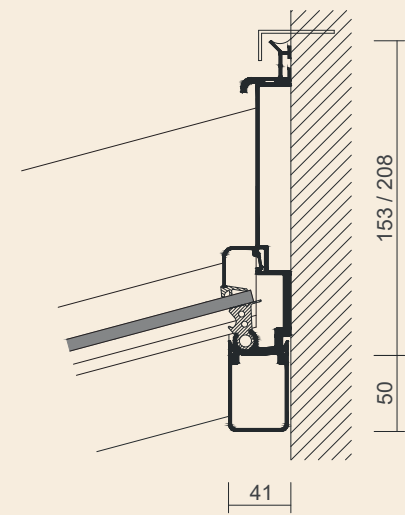

WALL JOINT

- One-piece wall joint for outside rafters
- Cable duct for concealed cable routing

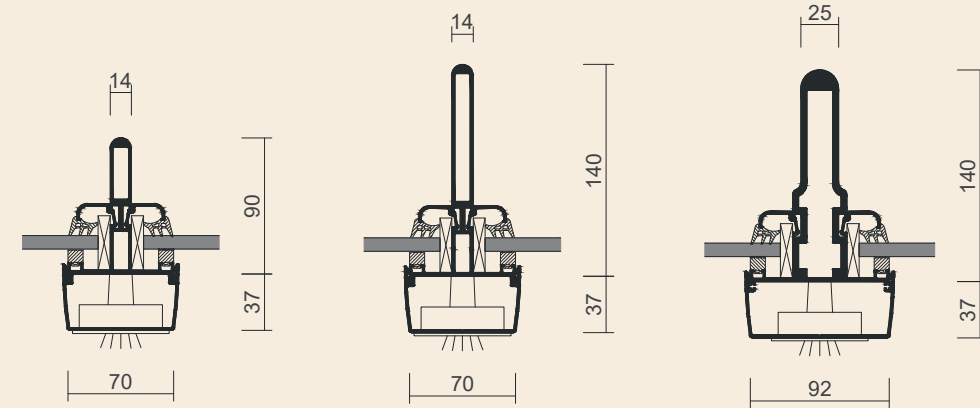

RAFTERS

- Three filig ee rafter types depending on structural requirements
- With optional spotlight rail

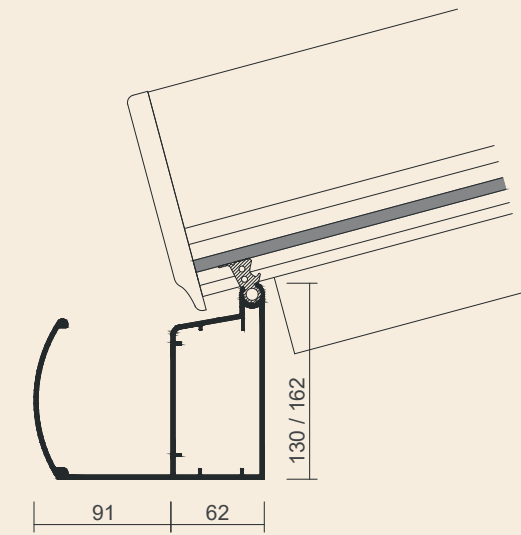

EAVES WITHOUT ROOF OVERHANG

- One-piece eaves with rounded Softline profil on the outside

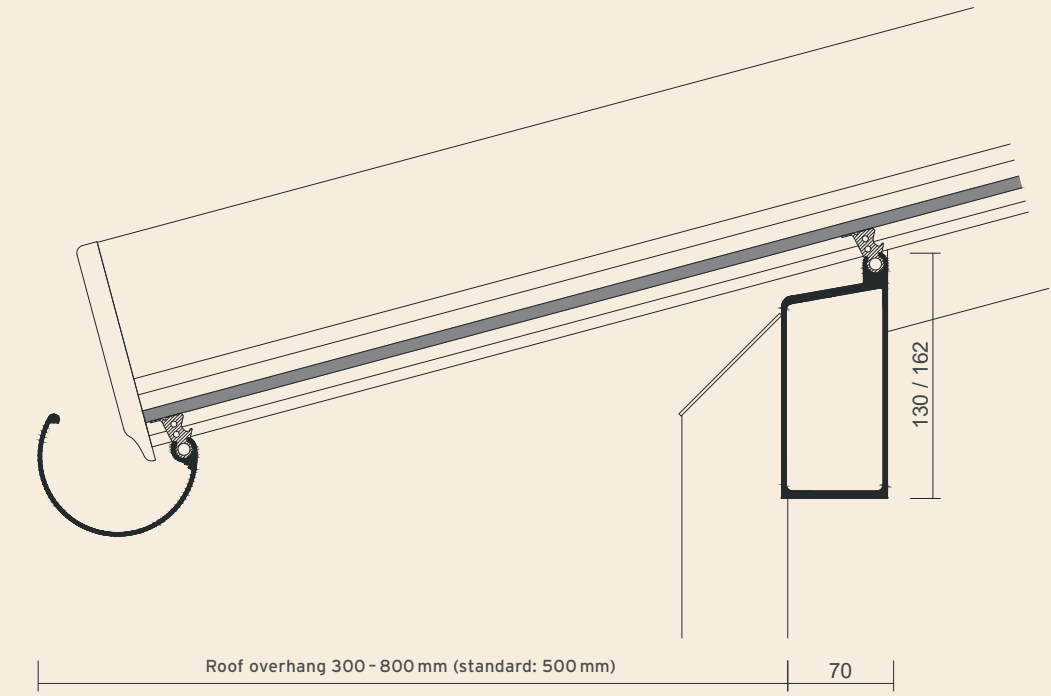

EAVES WITH ROOF OVERHANG

- Eaves for variants with variable roof overhang
- Drainage via external gutter

SDL AURA

Detail sections

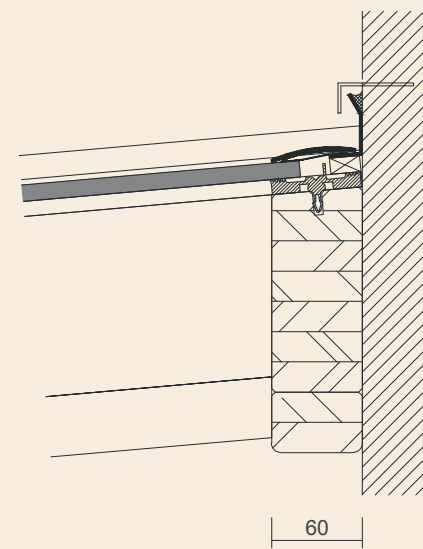

WALL JOINT

- Inside wall joint made of multi-laminate wood
- No visible screw connections
- With optional cable duct

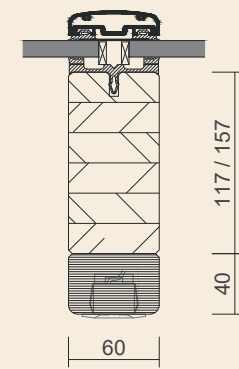

RAFTERS

- Filigree, inside rafters made of multi-laminate wood from certified forestry
- With optional surface-mounted spotlight rail (does not affect structural integrity of rafters)

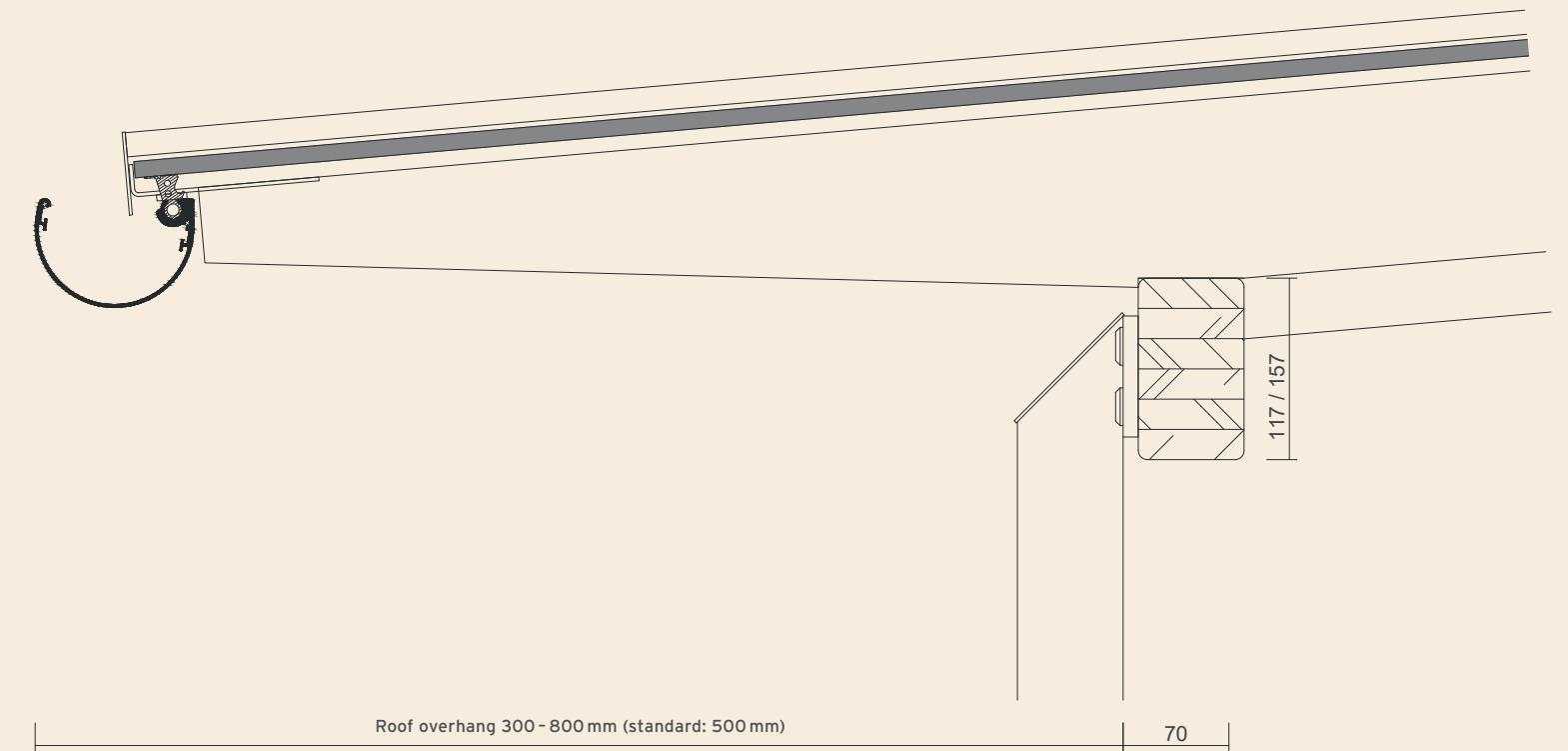

EAVES WITH ROOF OVERHANG

- Eaves made of laminated wood with variable roof overhang; rafter taper increases with length of roof overhang



PLACE YOUR TRUST
IN A STRONG *company*

ABOUT SOLARLUX



A SPECIAL FAMILY-OWNED COMPANY

Down-to-earth, innovative and passionate

For more than 35 years, Solarlux has represented exceptional quality in the production of bi-folding doors, wintergardens and facade solutions. Founded by Herbert Holtgreife and based in the town of Melle, north-west Germany, the company is now managed by Holtgreife's son, Stefan. But the real driving force behind Solarlux is its employees: A workforce of around 900 imaginative employees is vital for the success of the leading system provider.

The company's environmentally friendly approach to production, in-house production control structure and compliance with the highest quality standards are reflected in its ISO 9001, ISO 14001 and DIN EN 1090 certificates. When combined with the extensive community outreach that has been part of Solarlux ever since it was founded, this truly makes the family-owned company something special.

**"YOU CAN LOOK BACK, AND
YOU CAN LOOK TO THE FUTURE.
WE DO BOTH."**



THE WORLD OF SOLARLUX



WHAT DOES SOLARLUX STAND FOR?

- Family-owned company
- Certified in accordance with ISO 9001
- In-house Research and Development division
- 900 employees worldwide
- Successful projects in over 60 different countries
- Community outreach, sense of responsibility for people and nature



PRODUCTION

- 57,000 m² production site in north-west Germany
- State-of-the-art manufacturing machinery
- In-house painting line and powder coating plant
- Sustainable and energy-saving
- Certified in accordance with the ISO 14001 environmental standard



SOLARLUX PRODUCTS

- Made in Germany
- CE-approved
- Certified and independently tested
- Winner of national and international design awards
- Equipped with the best profile surface
- Comply with the strictest quality standards
- Custom products made to order



SOLARLUX SERVICE

- Top-class consultation
- Everything from a single source
- Tidy assembly
- Private and public building projects handled professionally
- Maintenance and service agreements that extend beyond project completion

KEEP TRACK OF SOLARLUX IN THE DIGITAL REALM

Stay up to date

Projects, references, news - the world of Solarlux moves fast, and an image is sometimes worth a thousand words. What more reason do you need to visit our website or the mySolarlux portal, or to follow us on social media?

It should go without saying that, even in this digital age, we love hearing from you directly and answering your questions in person or on the phone. So don't delay - contact us today! Whether you'd like a zero-obligation consultation session, a sketch of your personal idea, or simply an answer to your question, there are plenty of ways to get in touch with us.



